

**KIMERA**  
**Seamless Baby Cardigan**



**To Fit Size:** 0-3, (6-12, 18-24) months  
**Approximate Finished Chest Measurement:** 20", (22, 24)  
**Length:** 10 ½", (11, 12)  
**Sleeve Length:** 5 ½", (6, 7 ½)

**Materials:**

**Kimera:** 3, (3, 3)—50g balls,  
**color 16 Orange/Blue Mix**

**Gauge:** 24 sts, 32 rows= 4" in st st on US Size 4 (3.5mm) knitting needles,  
25 sts= 4" in beaded rib on US Size 4 (3.5mm) needles.

**Needles/Notions:** US Size 4 (3.5mm) 24" circular needle and DPNs, 4 st markers (m),  
4 st holders, 5 buttons from Dill (photographed is #268628-18mm)

Pattern is written for smallest size, with larger sizes in parenthesis. If only one number is given, it applies to all sizes.

**Beaded Rib** worked flat (Multiple of 2 sts + 1)

**Row 1 (RS):** K all sts.

**Row 2 (WS):** P1, \*k1, p1; rep from \* across.  
Rep these 2 rows for pattern st.

**Beaded Rib** worked in the rnd (Multiple of 2 sts)

**Rnd 1 (RS):** K all sts.

**Rnd 2 (WS):** \*K1, p1; rep from \* across. Rep these 2 rnds for pattern st.

Cardigan is worked from the bottom up in one piece. The sleeves are worked separately in the round. The sleeves are then joined to the body and is worked altogether to make the yoke.

**Body**

With circular needle, CO 117, (127, 139) sts. Work in beaded rib worked flat for 10 rows. Beg working in st st. When body measures 6", (6, 6 ½) from CO edge, end having worked a RS Row.

**Divide fronts from back**

**Next Row (WS):** P27, (30, 33) sts (left front), BO 2 sts, p59, (63, 69) sts (back), BO 2 sts, p27, (30, 33) sts (right front). 27, (30, 33) sts for each front, 59, (63, 69) sts for the back. Place all sts on a holder and set aside.

**Sleeve**

With DPNs, CO 36, (38, 40) sts. Join in the rnd and pm. Work in beaded rib worked in the rnd for 10 rnds. Beg working in st st (k every rnd), When sleeve measures 1 ¾", inc 1 st before and after the m on next and following 4th, (4th, 6th) rnd 6 times total. 48, (50, 52) sts. Work even until sleeve measures 5 ½", (6, 7 ½) from CO edge, ending 1 st before beg of rnd m on last rnd.

ABBREVIATIONS: beg= begin(ning), BO= bind off, CO= cast on, cont= continue, DPNs= double pointed needles, inc= increase, m= marker, patt= pattern, pm= place marker, p = purl, rem= remain(ning), rep= repeat, rnd=round, RS= right side, sl = slip, SSK = slip 1 st as if to knit, slip a second st as if to knit, knit them together through the back loop, st(s) = stitch(es), st st = stockinette st, tog = together, WS= Wrong Side

Next Rnd: (remove m) BO 2 sts, k to end of rnd. 46, (48, 50) sts. Set sleeve aside and make another sleeve.

Yoke- remember you are joining the sleeves together with the body at this point- you will be working across the right front, then the right sleeve, then the back, then the left sleeve then the left front.

(When working this section, you may find it difficult for the first couple rows to work across the sleeve sts since the underarm BO is very small. You may want to try using the DPNs for each section instead of the circular.)

With all RS facing, K24, (27, 30) sts, k2tog, k1 from right front, pm, K1, ssk, k40, (42, 44) sts, k2tog, k1 from one sleeve, pm, K1, ssk, k53, (57, 63) sts, k2tog, k1 from back, pm, K1, ssk, k40, (42, 44) sts, k2tog, k1 from one sleeve, pm, K1, ssk, k24, (27, 30) sts from left front.

(8 sts dec'd.) 197, (211, 227) sts. (Read through entire section before proceeding—you will be shaping the front neck as well as the raglan seams at the same time.)

Row 2 (WS): P all sts.

Dec Row (RS): \*K to 3 sts before m, k2tog, k1, sl m, k1, ssk; rep from \* 3 times more, k to end of row—8 sts dec'd. 189, (203, 219) sts. Cont to work the dec every RS Row 16, (18, 19) times more, while working every other WS Row in k to create a ridge—128, (144, 152) sts dec'd. **At the same time** dec 1 st at each neck edge on next and following 4th row 7, (6, 8) times. 47, (47, 51) sts rem when all shaping is complete- 2, (4, 4) sts for each front, 23, (23, 27) sts for the back, 10, (8, 8) sts for each sleeve. Place sts onto a holder.



Front Band

With RS facing and circular needle, pick up and k 33, (36, 45) sts along the right front to neck shaping, pick up and k 27, (30, 33) sts along the neck shaping to sts on holder, k 47, (47, 51) sts from holder, pick up and k 27, (30, 33) sts along the left neck shaping, pick up and k 33, (36, 45) sts along the left front to CO edge.

167, (179, 207) sts. Work in beaded rib worked flat for 4 rows, starting with a WS Row.

Buttonhole Row (for a boy) (WS): \*Pattern 5, (5, 7) sts, BO 2 sts; rep from \* 4 times more, pattern to end of row.

Buttonhole Row (for a girl) (WS): Pattern to last 35, (35, 45) sts, \*BO 2 sts, pattern 5, (5, 7) sts; rep from \* 4 times more. On next row, CO 2 sts over each BO section from previous row.

K3 more rows in pattern st and then BO all sts in k on next row. Sew 5 buttons onto the front. Sew the underarm seam. Weave in all ends. ©2014 Plymouth Yarn Company. 091514vle Designed by Vanessa Ewing 081816jbt

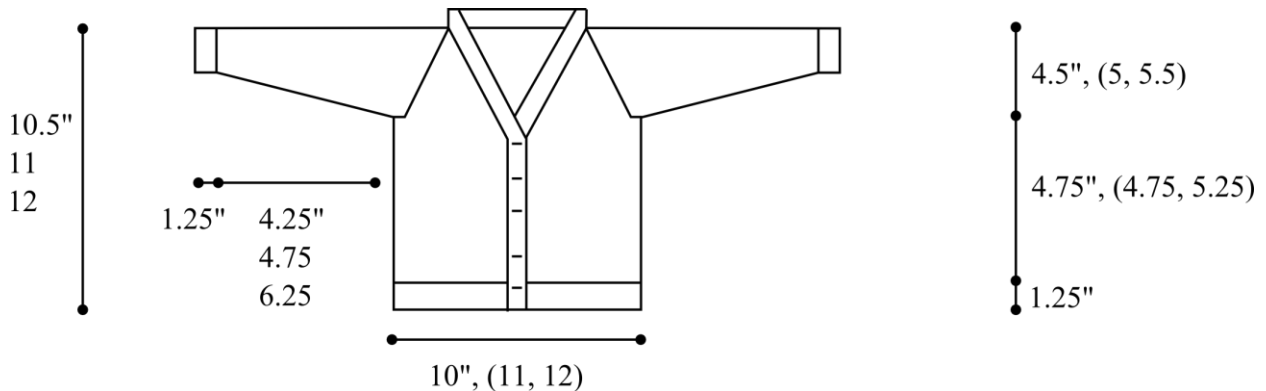

ABBREVIATIONS: beg= begin(ning), BO= bind off, CO= cast on, cont= continue, DPNs= double pointed needles, inc= increase, m= marker, patt= pattern, pm= place marker, p = purl, rem= remain(ning), rep= repeat, rnd=round, RS= right side, sl = slip, SSK = slip 1 st as if to knit, slip a second st as if to knit, knit them together through the back loop, st(s) = stitch(es), st st = stockinette st, tog = together, WS= Wrong Side